

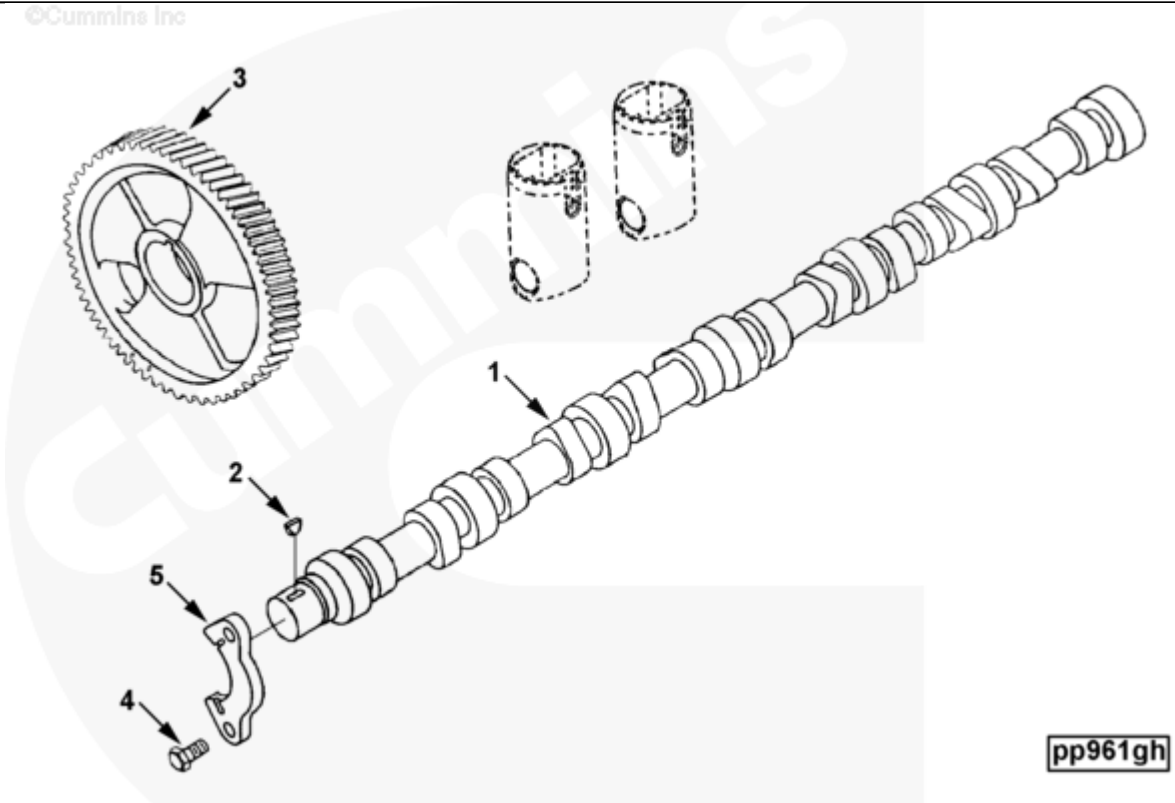

Parts Catalog - Option Detail

Electronic Parts Catalog - Option Detail				
Option	Group	Graphic	Film Card	Date
PP2664-02	01.07	pp961gh	Z	10-AUG-05
Engines	6C8.3, C GAS PLUS CM556, G8.3, G8.3 CM558, GTA8.3 CM558, ISC CM2150, ISC CM554, ISC CM850, ISC8.3 CM2250, ISC8.3 G CM2180 C101, ISL CM2150, ISL CM554, ISL CM850, ISL G CM2180, ISL8.9 CM2150 L110, ISL8.9 CM2880 L112, ISL9 CM2150 SN, ISL9 CM2250, ISL9 CM2350 L101, ISL9 CM2350 L111, ISLE4 CM850, L GAS PLUS CM556, L8.9, L8.9 L121, L8.9G CMOH2.0 L125B, L9 CM2350 L116B, L9 CM2350 L119B, L9 CM2350 L120C, L9 CM2350 L123B, L9.3 L105, L9.5 L117, L9N CM2380 L124B, QSC8.3 CM2250, QSC8.3 CM2880 C102, QSC8.3 CM554, QSC8.3 CM850(CM2850), QSL9 CM2250, QSL9 CM2250 L115, QSL9 CM2350 L102, QSL9 CM2350 L107, QSL9 CM2350 L118, QSL9 CM2350 L122, QSL9 CM554, QSL9 CM850(CM2850), QSL9 G CM558, QSL9 M CM2250 L106, QSL9.3 CM2880 L113			



SMALL | MEDIUM | LARGE

Cart	Ref No	Part Number	Part Description	Required	Remarks
View My Cart					
		PP2664-02	Camshaft		MR - CAMSHAFT...(More)
					Performance Parts for:
					6CTAA8.3 Litre
					Engine Family: C Series

				Reference CPL#: 2664
				Certified By: None
				Cylinders: 6
				Exh Mfld Type: Dry
				Aspiration: Charged Air
				Cooled
				Engine Control System: MRE
				Fuel Pump Manufacturing /
				Model: Bosch P3000
				Catalytic Converter Required:
				No
				High Pressure Fuel Line ID
				(mm): 1.8
				Unique Characteristics: With
				Edge Filter Injectors
				Cylinder Head Valve Material:
				Premium
				Cyl Head Valve Inserts: No
				Valve Bridge Scalloping: No
				Required Cylinder Head Swirl:
				Low
				Camshaft Gear Material:
				Steel
				Required Lube Pump Flow (GPM
				@ RPM): 27.5 at 2200
				Requires Graded Pistons: No
				Engine Design Phase: Current
				Product
				Base Turbo ID17: 3535749
				For Use With Electronic

					Governor Only
					Brazil May Use P/N 3934169
					Instead of 3935715
		3935715	Camshaft	1	
<input type="checkbox"/>	1	3923478	Camshaft	1	
<input type="checkbox"/>	2	3902332	Plain Woodruff Key	1	
<input type="checkbox"/>	3	3918777	Camshaft Gear	1	
<input type="checkbox"/>	4	3900227	Hexagon Head Cap Screw	2	M8 X 1.25 X 22.
<input type="checkbox"/>	5	3927155	Camshaft Thrust Support	1	

© 2019 Cummins Inc., Box 3005, Columbus, IN 47202-3005 U.S.A.
Terms of Use and Disclaimers | Recommended System Requirements
Need Assistance? Please click on the Contact Us button in the top right corner of any page.